

2011

Crab Crossing Consideration for MEIC

S. Ahmed

Y. Derbenev

Geoffrey A. Krafft

Old Dominion University, gkrafft@odu.edu

Y. Zhang

Subashini De Silva

Old Dominion University, pdesilva@odu.edu

See next page for additional authors

Follow this and additional works at: https://digitalcommons.odu.edu/physics_fac_pubs



Part of the [Engineering Physics Commons](#)

Original Publication Citation

Ahmed, S., Derbenev, Y., Krafft, G. A., Zhang, Y., De Silva, S. U., Delayen, J. R., & Castilla, A. (2011). *Crab crossing consideration for MEIC* [Paper Presentation]. PAC 2011 Contributions to the Proceedings, New York, New York. <https://accelconf.web.cern.ch/pac2011/papers/wep082.pdf>

This Conference Paper is brought to you for free and open access by the Physics at ODU Digital Commons. It has been accepted for inclusion in Physics Faculty Publications by an authorized administrator of ODU Digital Commons. For more information, please contact digitalcommons@odu.edu.

Authors

S. Ahmed, Y. Derbenev, Geoffrey A. Krafft, Y. Zhang, Subashini De Silva, Jean R. Delayen, and A. Castilla

CRAB CROSSING CONSIDERATION FOR MEIC *

S. Ahmed^{1†}, Y. Derbenev¹, G.A. Krafft^{1,2}, Y. Zhang¹, S.U. De Silva^{1,2}, J.R. Delayen^{1,2}, A. Castilla^{1,2}

¹Thomas Jefferson National Accelerator Facility, Newport News, VA 23606, USA

²Center for Accelerator Science, Old Dominion University, Norfolk, VA 23529, USA

Abstract

Crab crossing of colliding electron and ion beams is essential for accommodating the high bunch repetition frequency in the conceptual design of MEIC – a high luminosity polarized electron-ion collider at Jefferson Lab. The scheme eliminates parasitic beam-beam interactions and avoids luminosity reduction by restoring head-on collisions at interaction points. In this paper, we report the possible crabbing schemes and requirements for both electron and proton beams.

INTRODUCTION

The Medium Energy Electron-Ion Collider (MEIC) at Jefferson Lab has been envisioned as a first stage high energy particle accelerator beyond the 12 GeV upgrade of CEBAF. The beam and machine parameters for the proposed MEIC are illustrated in table 1. The high luminosity of $5.6 \times 10^{33} \text{ cm}^{-2}\text{s}^{-1}$ can be achieved by small beam sizes at the interaction point (IP) in conjunction with a large number of stored bunches having low charge per bunch (4 nC for electron, ~ 0.7 nC for proton) using the finite crossing angle scheme [1]–[3]. This requires the separation of two beams quickly to avoid parasitic collisions and the minimization of synchrotron-betatron resonance near the IP [4]–[7]. These requirements can be fulfilled by employing the crab crossing concept [1]–[2] first proposed by Palmer for linear collider [8] and later by Oide et. al. for storage rings [9]. Let us call this original scheme as “transverse crabbing” for the sake of comparison with “dispersive crabbing” which employs the existing accelerating RF cavities [2], [10]. In this paper, we will discuss the possible crabbing schemes and some of our latest developments.

TRANSVERSE CRABBING SCHEME

In this scheme, bunches are tilted by a time dependent transverse kick in RF cavities located before the IP in each ring and thereby collide essentially head-on. This tilt is kicked back to the original orientation in another deflector after the IP. We, therefore, need four crab cavities in the two rings corresponding to each IP where the betatron phase advance is $\pi/2+n\pi$ (n is an integer) from the IP. The RF phase of the deflector should be set such that the integrated Lorentz force is zero at the center of the bunch but the head

* Authored by Jefferson Science Associates, LLC under U.S. DOE Contract No. DE-AC05-06OR23177. The U.S. Government retains a non-exclusive, paid-up, irrevocable, world-wide license to publish or reproduce this manuscript for U.S. Government purposes.

[†] sahmed@jlab.org

Table 1: Beam and Machine Parameters for MEIC

Parameters	Proton	electron
E_b (GeV)	60	5.0
f_{rf} (MHz)	748.5	748.5
N_e (10^{10})	0.416	2.5
σ_l (mm)	10	7.5
I (A)	0.5	3
σ_E (10^{-4})	3	7.1
ϵ_x^n ($\mu\text{m-rad}$)	0.35	54
ϵ_y^n ($\mu\text{m-rad}$)	0.07	10.7
β_x^* (m)	0.1	0.1
β_y^* (m)	0.02	0.02
β_x^c (m)	1400	350
φ_{cross} (mrad)		50
L ($\text{cm}^{-2}\text{s}^{-1}$)		5.6×10^{33}

and the tail of the bunch experience deflections in opposite directions.

Requirements

In this section, we calculate several specific parameters of the scheme for electrons and protons. Considering two figure-8 rings, one for electron and other for proton for MEIC physics with asymmetric energies: 5 GeV and 60 GeV. The crossing angle of 50 mrad gives 175 mm and 350 mm separations for electron and proton beams at a distance of 3.5 m and 7 m respectively from the collision point. These separations provide adequate room to accommodate the final focusing quadrupoles for the e-beam and the p-beam and avoid the interference between them. The transverse kicking RF voltage is given by [9]

$$V = \frac{cE_b \tan \varphi_{\text{crab}}}{2\pi f_{\text{rf}} (\beta_x^c \beta_x^*)^{1/2}} \quad (1)$$

where E_b , $\varphi_{\text{crab}} = \varphi_{\text{cross}}/2$, f_{rf} , β_x^c and β_x^* are beam energy, crabbing angle, RF frequency, and beta functions at crab cavity location and IP respectively. The required RF voltage for electron and proton beams are 1.35 MV and 8 MV respectively.

The following accuracies are important to consider for the transverse crabbing scheme [9]. First, the relative phase stability $\Delta\theta$ between the crab cavities of two colliding beams. This phase error $\Delta\theta$ makes a relative horizontal displacement of both beams at IP. The tolerance is estimated as

$$\Delta\theta \ll \frac{2\pi f_{\text{rf}} \sigma_x^*}{c \tan \varphi_{\text{crab}}} = \frac{2\pi f_{\text{rf}}}{c \tan \varphi_{\text{crab}}} (\beta_x^* \epsilon_x)^{1/2} \quad (2)$$

which is about 14.7 mrad for both the beams. Second, the stability of the kicking voltage amplitude of cavities for two colliding beams. The amplitude error causes an error on the tilt angle and excites the synchrotron-betatron resonances [9]. It is expected that this effect is tolerable when the tilt-angle error is much smaller than the diagonal angle of the bunch (σ_x^*/σ_l) giving [9]

$$\frac{\Delta V}{V} \ll \frac{\sigma_x^*}{\sigma_l \tan \varphi_{\text{crab}}} \quad (3)$$

Hence $\Delta V/V$ should be much smaller than 0.125 and 0.097 for electron and proton beams.

The following issues are important to resolve in a transverse crabbing scheme [10]. First, the RF amplitude and phase tolerance. Second, the transverse transient beam loading. Third, the transverse beam instability. Fourth, the transverse second order gradient of the crab field which creates spread of kick across the beam area.

DISPERSIVE CRABBING SCHEME

This is an alternative crabbing scheme to preserve the luminosity by employing the commonly used accelerating/bunching superconducting RF cavities operating on basic axisymmetric mode. It requires dispersion function in the section where the cavity is installed. This idea was initially proposed by G. Jackson [10] where the kick in energy produced by the RF field excites betatron motion. Our analysis of the idea [2] is expressed as follows. Assume that cavity is installed in the section where the derivative of beta function $\beta' = d\beta(s)/ds$ of the extended beam is zero. To produce crab kick in betatron motion by the longitudinal E-field, it then requires non zero value of the first derivative of dispersion, $D' = dD(s)/ds$. Taking into account the continuity of particle's transverse motion (x, x'), the resulting change in betatron part of angle $\delta x'_b$ is found as follows

$$\delta x'_b = -D' \frac{\delta p}{p} = -D' \frac{V \sin \phi_{\text{rf}}}{E_b} \approx -D' \frac{V}{E_b} \frac{\omega s}{c} \quad (4)$$

where ϕ_{rf} is the rf phase, s is the particle's longitudinal coordinate with respect to the bunch center; for small RF phase $\sin \phi_{\text{rf}} = \phi_{\text{rf}} = \frac{\omega s}{c}$. Note that the dispersion is compensated before the final focusing quadrupoles and the kick in betatron angle is transformed by the focusing optics to particle's transverse position at IP which gives $x^* = \sqrt{\beta_x^c \beta_x^*} \delta x'_b$. The required crabbing voltage is then expressed as

$$V = \frac{c E_b \varphi_{\text{crab}}}{2\pi f_{\text{rf}} \sqrt{\beta_x^c \beta_x^*} D'} \quad (5)$$

The required RF voltage for the electron ($D' = 0.04$) and the proton ($D' = 0.16$) beams are 34 MV and 51 MV. The advantage of dispersive scheme is that there is no spread in the energy kick across the beam area.

CAVITY DEVELOPMENT

In this stage, we are exploring the best possible cavities for crabbing application. KEK-B factory has demonstrated their success in implementing the squashed-shape cavity by employing TM_{110} mode [7]. Recently, at Jefferson Lab a compact size deflecting/crabbing RF cavity has been proposed and designed [12] as shown in Fig. 1. This cavity provides kick to the beam particles through transverse electromagnetic (TEM) mode. It is important to note that the RF frequency of MEIC is 748.5 MHz and for details see [13, 14]; we are presenting the parameters scaled from the existing design at 499 MHz. The features of these two cavities are listed in Table 2.

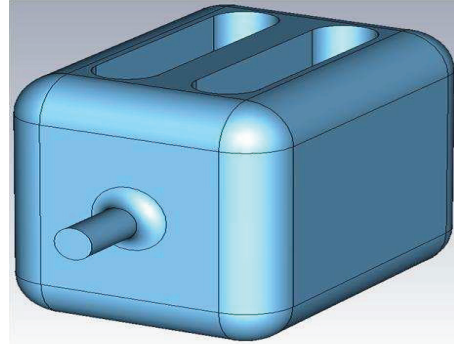

Figure 1: TEM-type superconducting cavity Ref. [12].

Table 2: Properties of TEM-type and KEK Crab Cavities

Parameters	TEM-type cavity	KEK Cavity
Frequency (MHz)	748.5	508.8
Length (mm)	200	300
Height (mm)	200	483
Aperture dia. (mm)	60	220
V_{def}^* (MV)	0.2	0.3
E_p^* (MV/m)	1.3	4.32
B_p^* (mT)	4.5	12.45
Geom. factor (Ω)	45	220
at $E_T^* = 1$ MV/m		

BEAM DYNAMICS SIMULATIONS

The detailed study of beam dynamics should address the issues like beam emittance dilution, phase and amplitude stabilities etc. However, in this stage we have studied the beam quality (emittance) and the complete beam dynamics simulations are under progress. In this study, we have used General Particle Tracer (GPT) [15]. The GPT simulation software package requires fieldmap of the cavity for tracking particle, which is obtained from the eigen mode solver of the CST Microwave Studio [16]. GPT is a well established three-dimensional time domain computer program for studying the particle dynamics in EM fields. The tracking algorithm is based on the fifth order Runge-Kutta

method with adaptive step size and takes into account the space charge physics and other nonlinearities.

In this stage, we are showing the first calculation of beam emittance for the TEM-type superconducting cavity (499 MHz) shown in Fig. 1. We start tracking particles consisting of 1000 electrons having uniform distribution (zero initial emittance) with bunch length = 7.5 mm and radius = 2 mm. We expect the emittance dilution in the direction of kick which is along x in the cavity. This is indeed seen in Fig. 2. The theoretical estimate of emittance for the uniform beam follows the relationship

$$\epsilon_n^{rms} = \frac{eV_{def}}{4\sqrt{3}m_e c^2} \kappa r_b \sigma_l \quad (6)$$

where V_{def} is the deflecting voltage, r_b is the beam radius and $\kappa = 2\pi/\lambda$ is the wave number. Substituting the values of the parameters gives 60 mm-mrad which is exactly the simulated value. Similarly, the emittance dilution for different radius of bunch is shown in Fig. 3 which confirms the linear relationship of emittance with radius. It is important to note that this correlated emittance after many turns could transform to uncorrelated emittance due to filamentation. To prevent such transform, our scheme includes compensated cavity located symmetrically after the collision point.

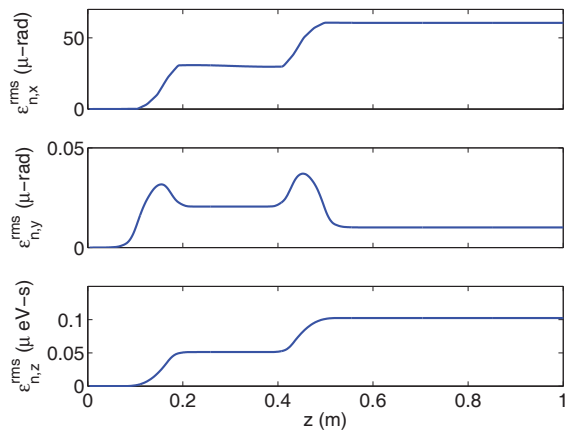

Figure 2: Evolution of emittance along the z -direction for 7.5 mm bunch length and 2 mm bunch radius of uniformly distributed beam with zero initial emittance.

CONCLUSION

We have studied the transverse and dispersive crabbing schemes for MEIC at Jefferson Lab. The requirements for both the electron and the proton beam have been reported in the paper. The transverse crabbing scheme requires low voltage, however, the dispersive cavity need relatively high voltage but employ the existing superconducting RF technology. First calculation of beam emittance using the proposed design of TEM-type superconducting cavity shows dilution to the order of 10^{-6} . The details of the beam dynamics are under our future scope.

Beam Dynamics and EM Fields

Dynamics 02: Nonlinear Dynamics

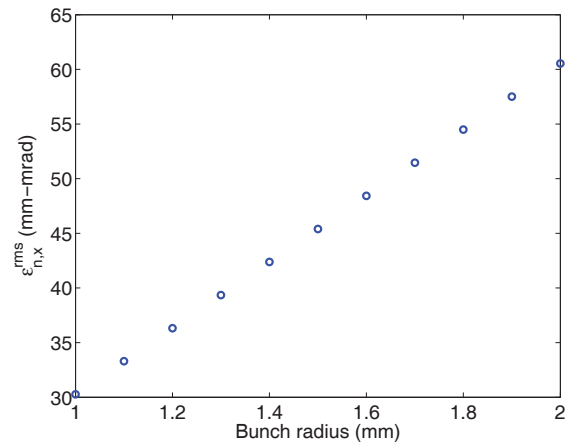

Figure 3: Emittance growth versus bunch radius for 7.5 mm bunch length of uniformly distributed beam with zero initial emittance.

REFERENCES

- [1] Y. Derbenev, Advanced Concepts for Electron-Ion Collider, in Proceedings of the 2002 EPAC 2002, Paris, France, p. 314 (2002).
- [2] Y. Derbenev, Advances in Collider Concepts, Talk delivered at EIC workshop, Stony Brook, USA, Jan. 10-12, 2010.
- [3] P. Wiesmann, Colliding a Linear Electron Beam with a Storage Ring Beam, Nucl. Instrum. Methods, 279, p. 21 (1989).
- [4] A. Piwinsky, Space Charge Effect With Crossing Angle, Nucl. Instrum. Methods, 81, p. 199 (1970).
- [5] A. Piwinsky, Satellite Resonances Due to Beam-Beam Interaction, IEEE Trans. Nucl. Sci., NS-24, p. 1408 (1977).
- [6] A. Piwinsky, Computer Simulation of the Beam-Beam Interaction at a Crossing Angle, IEEE Trans. Nucl. Sci., NS-32, p. 2240 (1985).
- [7] K. Akai et. al., RF Systems for the KEK B-Factor, Nucl. Instrum. Methods A, 499, p. 45 (2003).
- [8] R.B. Palmer, Stanford Linear Accelerator Center Report No. SLAC-PUB-4707, 1988.
- [9] K. Oide and K. Yokoya, Beam-beam collision scheme for storage-ring colliders, Phys. Rev. A 40, No. 1, p. 315 (1989).
- [10] G. Jackson, Dispersive Crab Crossing: An Alternative Crossing Angle Scheme, Fermilab Tech. Note. FN-542, (May 03, 1990).
- [11] A. Piwinsky, CERN 87-03 (1987).
- [12] J. Delayen and H. Wang, Phys. Rev. ST. Accel. Beams, 12, 062002 (2009).
- [13] J.R. Delayen and S.U. De Silva, Design of superconducting parallel-bar deflecting/crabbing cavities with improved properties, in proceedings of this PAC, New York, USA (2011).
- [14] S.U. De Silva and J.R. Delayen, Fundamental and HOM coupler design of the superconducting parallel-bar cavity, in proceedings of this PAC, New York, USA (2011).
- [15] General Particle Tracer, <http://www.pulsar.nsl>.
- [16] CST Microwave Studio, <http://www.cst.com>.